

SPEAKER POWER AND DISTANCE

Speaker Sensitivity

When designers and engineers consider a speaker to integrate into their product, most focus on the speaker's power handling as a gauge of how loud a speaker can play and its quality.

More attention needs to be paid to the sensitivity rating of a speaker, which we call out as the SPL rating on our speaker specifications. This SPL rating is listed with a given input at a fixed distance. When both the power handling and SPL rating are considered, one can start to get the true picture of a speaker's maximum output capability.

Let's look at one of our louder speakers, the AS06608PS-R.

SPECIFICATIONS			THIS DOCUMENT CONTAINS DATA PROPRIETARY TO PROJECTS UNLIMITED, INC. ANY USE OR REPRODUCTION, IN ANY FORM, WITHOUT PRIOR WRITTEN PERMISSION OF PROJECTS UNLIMITED, INC. IS PROHIBITED. ©2003, Projects Unlimited Inc.	REVISION HISTORY			
PARAMETERS	VALUES	UNITS		LTR	DESCRIPTION	DATE	APPROVED
RATED INPUT POWER	4	W	-	RELEASED FROM ENGINEERING	9/12/2005		
MAX INPUT POWER	5	W	A	REVISED TO INVENTOR 3-D DRAWING TEMPLATE	1/19/2009	B.R.	
IMPEDANCE	$8 \pm 15\%$	OHM	B	REVISED HOLE TO HOLE DIMENSION	9/13/2013	M.L.	
OUTPUT SPL @ 1W/0.5M (AT 1.0, 1.4, 1.7, 2.0 kHz)	95 ± 3	dBA	C	REVISED ROHS STATUS	9/13/2013	M.L.	
DISTORTION (MAX.)	5%	-					
RESONANT FREQUENCY	$230 \pm 20\%$	Hz					
FREQUENCY RANGE	230 ~ 12,000	Hz					
HOUSING MATERIAL	METAL	-					
CONE MATERIAL	PAPER	-					
MAGNET MATERIAL	FERRITE	-					
OPERATING TEMPERATURE	-20 ~ +50	°C					
WEIGHT	204	grams					

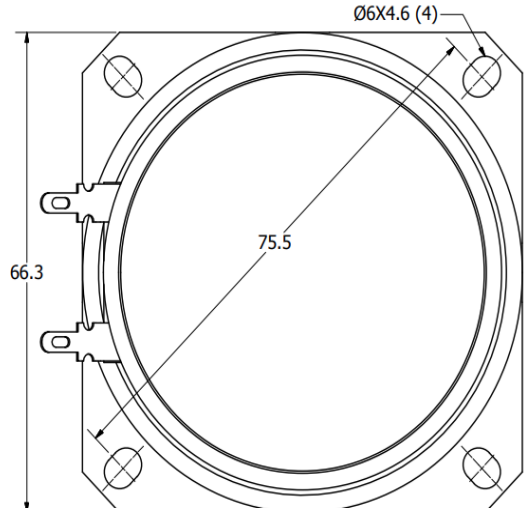

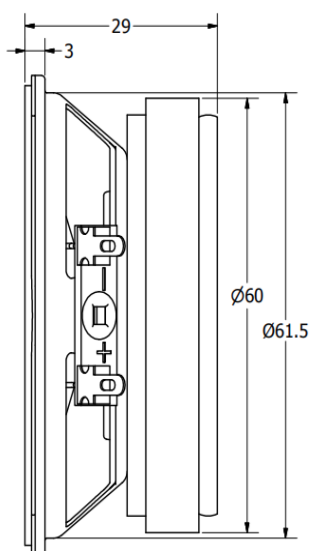

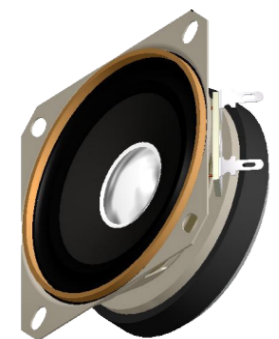

NOTES:

- ALL DIMENSIONS ARE IN MILLIMETERS.
- SPECIFICATIONS SUBJECT TO CHANGE OR WITHDRAWAL WITHOUT NOTICE.
- THIS PART IS RoHS 2011/65/EU COMPLIANT.

UNLESS OTHERWISE SPECIFIED: DIMENSIONS ARE IN MILLIMETERS, TOLERANCES ARE ±0.5 AND ANGLES ARE 45°.	SIZE	Designed by	Date	Checked by	Date	Approved by	Date	Drawn Date	
	A3	J.A.F.	9/12/2005	B.R.	9/12/2005	E.P.	9/12/2005	1/19/2009	
AS06608PS-R.idw			AS06608PS-R			Speaker		Edition	Sheet
						-	1 / 1		

The SPL rating is highlighted in yellow above. This speaker has an average output of 95 dB (when measured at 1, 1.4, 1.7, and 2 kHz) with a given input of 1 watt and measured at a distance of half a meter.

Power handling, highlighted in green above, is listed at 4 watts continuous and 5 watts maximum. Maximum power handling is the amount of power the speaker can take for brief moments.

With the sensitivity rating and the power handling for this speaker now known, we can move to the table below to see what effect increasing power will have on it.

The Effect of Power on SPL

You have to double the input power to produce a 3 dB increase in sound output (assuming the speaker is not reaching its limits). Therefore, we can produce a table for how loud the speaker will play with a specific starting power (On Right)

For each doubling of input power to the speaker, there will be a 3 dB increase in output. Take note of the power handling limit highlighted in yellow. What this illustrates is that additional power only adds a small amount of additional sound pressure over the initial SPL measured with 1 watt of input power. With most speakers, 80% to 90% of their maximum output is generated in that first watt.

Power in Watts	Volume in dB
1	95
2	98
4	101
8	104
16	107
32	110
64	113
128	116
256	119
512	122

Many customers exceed the speaker's power rating to squeeze just a little more output from a speaker. While this might not immediately damage the speaker, it does place additional stress on the tinsel leads (circled in red below) that connect the electrical terminals to the speaker's voice coil. If stressed for too long, these will break, and the speaker will fail to operate.

Sending a clipped signal can also damage the tinsel leads, as well as overheat the voice coil. This is mostly due to the speaker being forced to its inner and outermost positions for too long.



The Effect of Distance on SPL

Another consideration to take into account is distance. A speaker with the sensitivity rating of 95 dB @ 1W/50cm, has the same SPL as a speaker rated at 89 dB @ 1W/1m and the same as a speaker rated at 109 dB @ 1W/10 cm.

This is due to a ~6 dB increase with each halving of the measurement distance, and a 20 dB increase when decreasing the distance to 1/10 of the original, giving us the tables below.

SOUND PRESSURE LEVEL Vs DISTANCE			
Sound pressure loss in free space			
Distance (m)	dB drop	Distance (m)	dB drop
1	0	26	28.30
2	6.02	27	28.63
3	9.54	28	28.94
4	12.04	29	29.25
5	13.98	30	29.54
6	15.56	31	29.83
7	16.90	32	30.10
8	18.06	33	30.37
9	19.08	34	30.63
10	20.00	35	30.88
11	20.83	36	31.13
12	21.58	37	31.36
13	22.28	38	31.60
14	22.92	39	31.82
15	23.52	40	32.04
16	24.08	41	32.26
17	24.61	42	32.46
18	25.11	43	32.67
19	25.58	44	32.87
20	26.02	45	33.06
21	26.44	46	33.26
22	26.85	47	33.44
23	27.23	48	33.62
24	27.60	49	33.80
25	27.96	50	33.98

SOUND PRESSURE LEVEL Vs DISTANCE			
Sound pressure loss in free space			
Distance (cm)	dB drop	Distance (cm)	dB drop
10	0	260	28.30
20	6.02	270	28.63
30	9.54	280	28.94
40	12.04	290	29.25
50	13.98	300	29.54
60	15.56	310	29.83
70	16.90	320	30.10
80	18.06	330	30.37
90	19.08	340	30.63
100	20.00	350	30.88
110	20.83	360	31.13
120	21.58	370	31.36
130	22.28	380	31.60
140	22.92	390	31.82
150	23.52	400	32.04
160	24.08	410	32.26
170	24.61	420	32.46
180	25.11	430	32.67
190	25.58	440	32.87
200	26.02	450	33.06
210	26.44	460	33.26
220	26.85	470	33.44
230	27.23	480	33.62
240	27.60	490	33.80
250	27.96	500	33.98

Keep in mind that this works in reverse as well. A speaker rated at 95 dB at 10 cm will measure 75 dB at 1 meter and a speaker with a rating of 100 dB at 1 meter will measure 106 dB at 50 cm or 84.44 dB at 6 meters.

Now that we have done the math, let us look at where this leaves us.

If you need a measured sound pressure level of 80 dB at 3 meters, and you have 4 watts available from your amplifier, the needed sensitivity at 1 watt and measured at 1 meter would be 83.54 dB and the speaker would need to have a rated input power of 4 watts.

Here is how we arrived at that number:

- Add 9.54 to 80 to arrive at what SPL the speaker will need to achieve at 1 meter.
- Subtract 6 dB for the amount of gain from the power increase from 1 watt to 4 watts.